

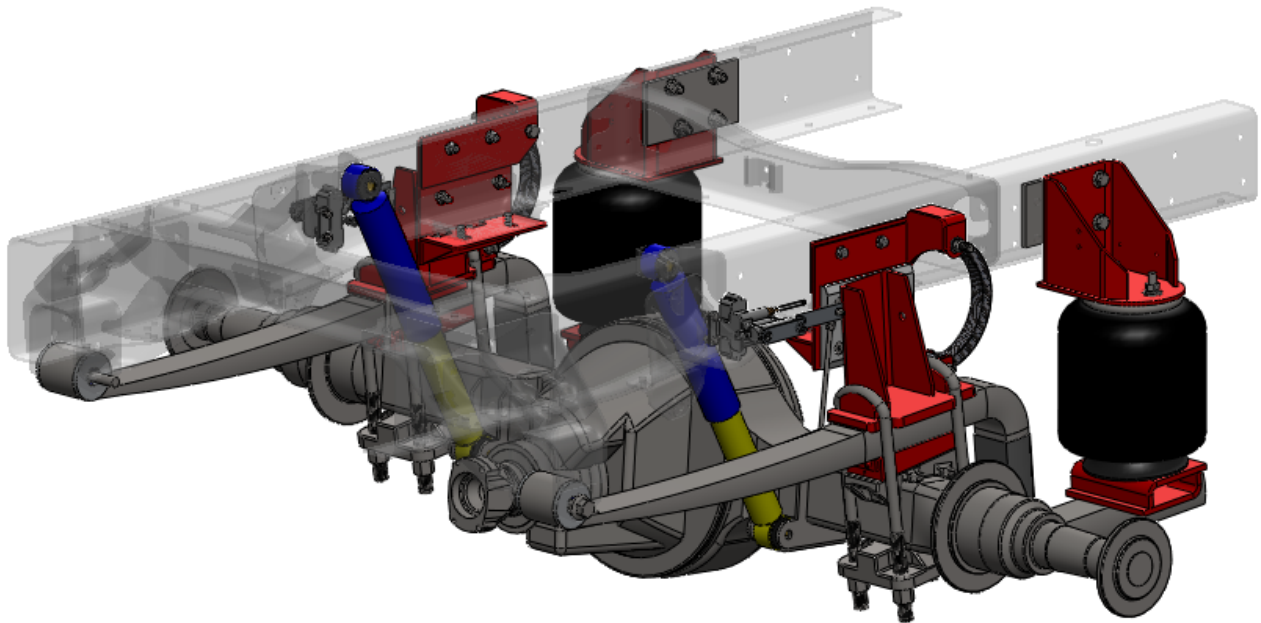

**SERVICE MANUAL
FOR DODGE 4500
RD1200DA SUSPENSION**



1805 West 800 South, P.O. Box 610
Franklin, Indiana, USA 47923
Tel: 219 279-2800 Fax: 219 279-2390
www.tuthill.com

D708777
REV E
11/16/09

TABLE OF CONTENTS

Introduction.....	3
Company Profile	3
About This Manual	6
General Information.....	7
Identification.....	7
Controls.....	8
Parts List	9
Inspection & Maintenance	12
Height Control Valve Inspection & Adjustment	12
Torque Specifications	13
Maintenance Schedule	15
Maintenance Record	16
Troubleshooting.....	17
Air Controls	19
-4 System 9930 Height Control Valve System with kneeler valves.....	19
-5 System 9932 Height Control Valve System w/o kneeler valves.....	22
-AB System K706859 Height Control Valve System w/ ping tanks and kneeler valves ..	25
-QR System K709308 Quick Recovery Air System.....	28
9905 Auxiliary “Ping” Tank Kit.....	31
Replacement Instructions and Warranty.....	32
Installation Instruction	33
Installation Check Sheet	37

INTRODUCTION

Company Profile

Tuthill Transport Technologies is the “Line of Business” name arising from the acquisition and merger of two companies in the heavy-duty suspension and off-road axle industries. Fluidrive®, Inc. of Brookston, IN, which included the Granning® brand; and Reyco® Industries, Inc. operating in Springfield, MO, Mt. Vernon, MO, and Grimsby, ON, Canada.

Tuthill Transport Technologies is certified to the internationally recognized ISO 9001:2000 Standard. This certification includes ReycoGranning® operations.

ISO 9001:2000 is the highest international quality standard and is recognized worldwide by all major countries and corporations. To obtain certification a company must undergo a series of rigorous audits to remain certified and ensure consistent quality standards are being maintained. This quality standard was developed by the International Organization of Standardization. Tuthill Corporation is a privately held manufacturing company with facilities worldwide. Tuthill’s corporate offices are located in Burr Ridge (Chicago), Illinois.

Granning was founded in Detroit, MI in 1949 and became part of Fluidrive, Inc in 1985. Reyco® was founded in Springfield, MO in 1924 as Reynolds Mfg Co and assumed the Reyco® Industries, Inc name in 1956. Reyco Canada was established in 1963 with the opening of a facility located in Grimsby, Ontario, followed by the opening of another Reyco facility in Mt Vernon, MO in 1973. Most recently, in 2003, the Reyco Springfield facility merged with the Reyco Mt. Vernon location to consolidate the Reyco line of products.

Tuthill Corporation purchased Fluidrive, Inc. in December 1998 and then purchased Reyco Industries, Inc in February 1999 to offer Reyco Granning® suspension solutions. Reyco Granning air and steel spring suspensions are sold to truck, trailer and specialty vehicle OEM’s, as well as truck equipment distributors. All products are designed, tested, manufactured and marketed by members of the Reyco Granning team.

Congratulations on your purchase of a ReycoGranning® **AIRGLIDE®** drive axle air suspension system. Founded in 1948 by one of the pioneers of air suspensions, ReycoGranning® Air Suspensions supplies drive and tag axle air suspension systems to a variety of original equipment manufactures as well as to the aftermarket industry. The R-Series, trade named **AIRGLIDE®**, are utilized by OEM customers in applications such as recreational vehicles, shuttle bus, trailer, chassis builders, Type I and III ambulances and class 3 through 8 truck applications. This product line now exceeds 25 models that cover all major chassis utilized in the above applications.

Suspension Description

A ReycoGranning® **AIRGLIDE®** drive axle air suspension system is a replacement rear suspensions system that consists of an air control system, air springs, trailing arm beams, brackets, and mounting hardware. In general, the air suspension works by maintaining a constant ride height by adjusting the amount air pressure in the air springs. This allows the vehicle to remain level, regardless of loading. By varying the amount of air pressure in the springs, a comfortable ride is maintained whether lightly or heavily loaded. This is the major difference between an air suspension and a conventional steel spring suspension. The steel spring suspension is usually designed for heavily loaded condition and thus yields a harsh ride in lightly loaded conditions. In addition, the steel spring suspension does not maintain a constant ride height under varying load conditions.

INTRODUCTION

By maintaining a constant ride height, the horizontal center of gravity, steering geometry, and even the headlights remain level. The benefits of an air ride are:

1. Driver/passenger comfort,
2. Protection of cargo, chassis and body components,
3. Reduced stress fatigue to chassis frame rails.
4. Greater stability and control.

A unique feature to the ReycoGranning® **AIRGLIDE**® drive axle air suspension system is the wear towers and wear blocks. These time proven components prevent unwanted side to side lateral motion without the use of costly and complex track rods.

Air Control System

A primary subsystem of a ReycoGranning® **AIRGLIDE**® drive axle air suspension system is the air control system. Depending on the actual system used, the air control system will provide the ability to automatically control the amount of air pressure in the air springs, thus automatically control the suspension ride height.

The major components of an automatic air control system consist of an air compressor, reservoir tank, height control valve, and air spring. The operation of the system is simple. The compressor supplies air to the tank, which maintains the air pressure between 95 - 125 psi. Air from the tank is supplied to the height control valve. The height control valve supplies air to or depletes air from the air spring via a mechanical linkage based on axle loading. The pressure changes in the air spring but the height remains the same, thereby giving the optimum ride regardless of load.

A system with a single height control valve supplies both air springs simultaneously while a dual height control valve system supplies each air spring separately. The dual system increases the sensitivity of side-to-side distributions of axle loading. A schematic of each system can be found in the Air Control System Parts List section. See Air Control System - Control Panels and Operation sections.

Located on the bottom of the air tank assembly, is a heated moisture ejector valve. (The valve is heated to eliminate ice build up.) This valve automatically releases accumulated water from the air tank every time the driving brake is used. Each time the driver presses the brake pedal, the ejection valve releases a bit more water, insuring a well drained system.

There is a small round button/port in the center of the underbelly of this valve. Press this button with your finger to manually drain accumulated water from the tank when the vehicle is turned "off".

Optional "kneeler" or exhaust valve(s) may be plumbed between the air springs and the height control valve(s). When power is applied to these valves, they shut off air supply from the height control valve to the air springs and exhaust air from the air springs. As long as power is supplied to the "kneeler" valve, usually through the "exhaust" position of the "inflate/exhaust" switch, the air springs will remain deflated. With the air springs deflated, the rear end of the vehicle will remain lowered, or "kneeled", with the chassis resting on positive jounce stops. Removing power to the "kneeler" valve allows air to flow from the height control valve to the air springs and shuts off exhaust from the air spring, thus inflating the air springs. The rear end of the vehicle is automatically raised to the proper ride height. Systems with dual height control valves require two "kneeler" valves, one between each air spring and height control valve, if the exhaust option is equipped.

To further improve the ride of an air suspension, ReycoGranning® offers a dual ping tank kit. One ping tank is added to each side between the air spring and the height control valve, or "kneeler"

INTRODUCTION

dump valve if installed. These 200 cubic inch ping tanks effectively increase the volume of the air spring, without having to utilize a larger air spring. The spring rate of a system is directly proportional to the volume of the air spring. The larger the air spring volume, the lower the spring rate; thus the better the ride. However, the amount of air flowing between the air spring and ping tank can limit the effective air volume of the system. Therefore, adding larger and larger ping tanks may not result in significant changes in the suspension spring rate. ReycoGranning® ping tank kits have been designed to provide the ideal increase in volume and proper airflow.

A side effect in adding ping tanks is possible increase in air spring inflation times. With a ping tank system installed, the larger volume of air, which improves the spring rate, must be refilled each time the system is "kneeled". ReycoGranning® ping tank kits have been designed to minimize this effect, while improving the ride.

Finally, optional warning light sensors or air pressure gauges may be plumbed to either the air reservoir tank or to the air springs. These warning devices will indicate possible problems with the air suspension system prior to operation. Gauges that are plumbed to the reservoir tank will read between 95 and 125 psi, as described above. Any air gauge that is plumbed directly to the air spring will show fluctuations depending on axle loading and vehicle operation.

INTRODUCTION

About This Manual

This publication is intended to acquaint and assist maintenance personnel in the maintenance, service, repair and rebuild of the **Reyco Granning**[®] RD1200DA Rear Suspension. It is important to read and understand the entire Technical Procedure publication prior to performing any maintenance, service, repair, or rebuild of this product

Reyco Granning[®] Air Suspensions reserves the right to modify the suspension and/or procedures and to change specifications at any time without notice and without incurring obligation. Contact customer service at 800-753-1060 for information on the latest version of this manual.

You must follow your company safety procedures when you service or repair the suspension. Be sure you read and understand all the procedures and instructions before you begin work on the suspension.

Reyco Granning[®] uses the following types of notes to give warning of possible safety problems and to give information that will prevent damage to equipment.



WARNING

A warning indicates procedures that must be followed exactly. Serious personal injury can occur if the procedure is not followed.



CAUTION

A caution indicates procedures that must be followed exactly. Damage to equipment or suspension components and personal injury can occur if the procedure is not followed.

NOTE

A note indicates an operation, procedure or instruction that is important for correct service.

Some procedures require the use of special tools for safe and correct service. Failure to use these special tools when required can cause personal injury or damage to suspension components.

The latest revision of this publication is available online at <http://www.Reyco Granning.com/> **Reyco Granning**[®] Air Suspensions has developed this service manual to aid in the maintenance of **Reyco Granning**[®] 's rear suspensions. General Notes

The following table lists the various models and their respective capacities.

Model	Capacity	Axle Capacity
RD1200DA	12,000 lbs	13,500 lbs

GENERAL INFORMATION

Overloading the suspension may result in adverse ride and handling characteristics.

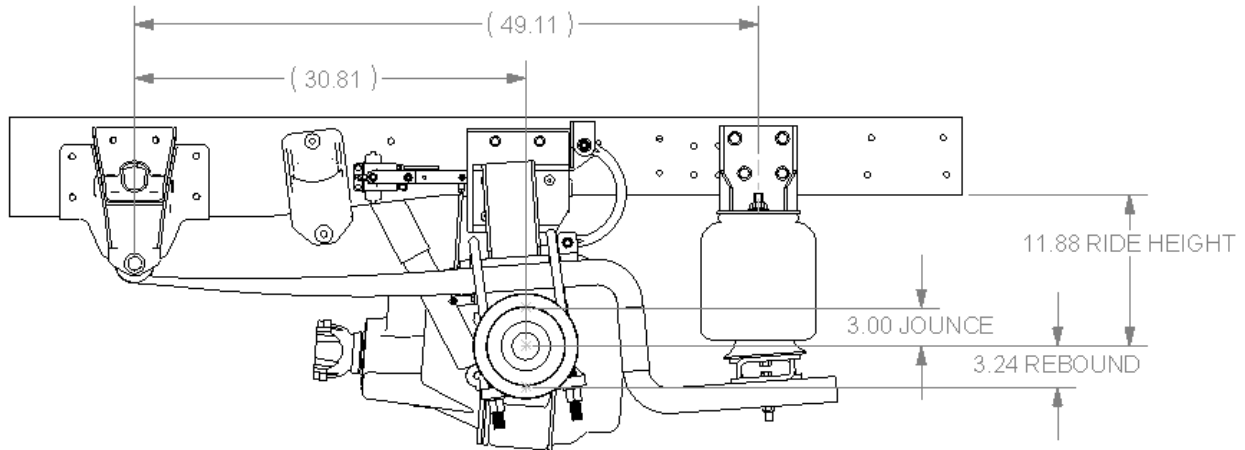

Note: The ride height is for the completed vehicle with body and components. See table below for correct vehicle dimensions. See following pages for the above views.

Chassis	Reyco Granning® Suspension Model	Ride Height *	Jounce Travel	Rebound Travel
Dodge 4500 SuperDuty Cab Chassis	RD1200D	11.88"	3.00"	3.24"

Ride height is measured from the axle center (flat and level) to the bottom of the vehicle frame at the rear of vehicle, behind the axle as shown.

Identification

The suspension model and serial number are stamped on an aluminum tag that is riveted to the driver side upper Hanger Weldment (See Figure 2). The serial number is used by **Reyco Granning**® for control purposes and should be referred to when servicing the suspension (See Figure 1).

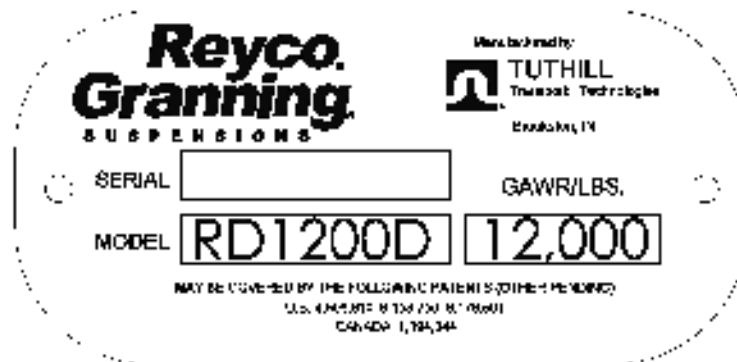

Figure 1: Suspension Identification

CONTROLS

Descriptions of the typical controls are found below. Note: some original equipment manufactures (OEM) will use controls integrated into the instrument panel. While the appearance may differ, the operation and description are consistent with below.

Power ON/OFF Switch

This master switch turns the power off and on to the compressor and other electrical components of the drive axle suspension. To activate the compressor and other electrical components, move the switch to "ON". The vehicle ignition switch may need to be turned on to activate this switch.

Exhaust/Inflate Switch

If the system is equipped with an optional "kneeler" exhaust valve(s), the control panel will have an Exhaust/Inflate switch. Moving

the switch to "Exhaust" position exhausts all air from the air springs. While the switch is in the "Exhaust" position, the air springs will remain deflated. Exhausting air from the air springs may be required to: assist in maintenance and lower the rear of the vehicle to assist in loading. **Caution:** Only operate the exhaust feature while the vehicle is parked. Never exhaust the system while the vehicle is in motion. To inflate the air springs, place the switch in the "Inflate" position.

Gauges, Lights, Buzzers

As an option, the Air Pressure Warning Light/Buzzer kit may be installed. The gage will indicate air tank pressure. If air pressure falls below 20 psi, a warning light and buzzer will activate. Do not operate the vehicle in this condition. The buzzer/light will go off once 40 psi air pressure is reached.

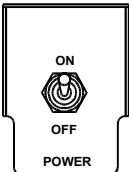
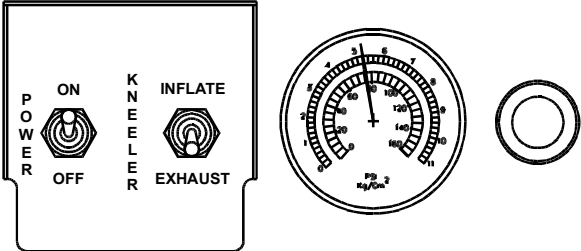
	<p>The 5016 Control Panel Assembly, with Power ON/OFF only. Included with the 9932 Air Control Kit.</p>
	<p>The 5008 Control Panel Assembly, with Power ON/OFF and "Kneeler" Dump Valve Switches. Also shown is the 1069 Air Pressure Gauge (0-160 psi) and the 5401 Alarm Light/Buzzer. The 5008 Control Panel Assembly is included with the 9930 Air Control Kit. The 1069 Gauge and 5401 Light/Buzzer are included in the optional 5703 Warning Kit. Air pressure sensing may also be performed by and OEM installed interface (control panel).</p>

Operation of the ReycoGranning® **AIRGLIDE**® drive axle suspension utilizing an automatic height control system is reached through various control panels. Depending upon options included with the suspension system, the control panel should be operated as follows:

Before operating the vehicle:

- Switch the power to "ON", if "OFF".
 - Make sure the Exhaust/Inflate switch is in the "Inflate" position, if the suspension is so equipped.
 - If equipped, check that the Low Pressure Warning Light and Buzzer is off.
- The vehicle is ready for operation.

To exhaust the system, if the suspension is equipped with an exhaust option:

- Make sure the vehicle is parked.
- Move the Exhaust/Inflate switch to the "Exhaust" position.
- When exhausted, switch the power to "OFF" (if desired).

Although the air suspension master power switch can be left "ON", ReycoGranning® recommends turning the system off while the vehicle is parked for an extended period, if the suspension system is not switched through the vehicle ignition switch. This will avoid running down the battery.

PARTS LIST

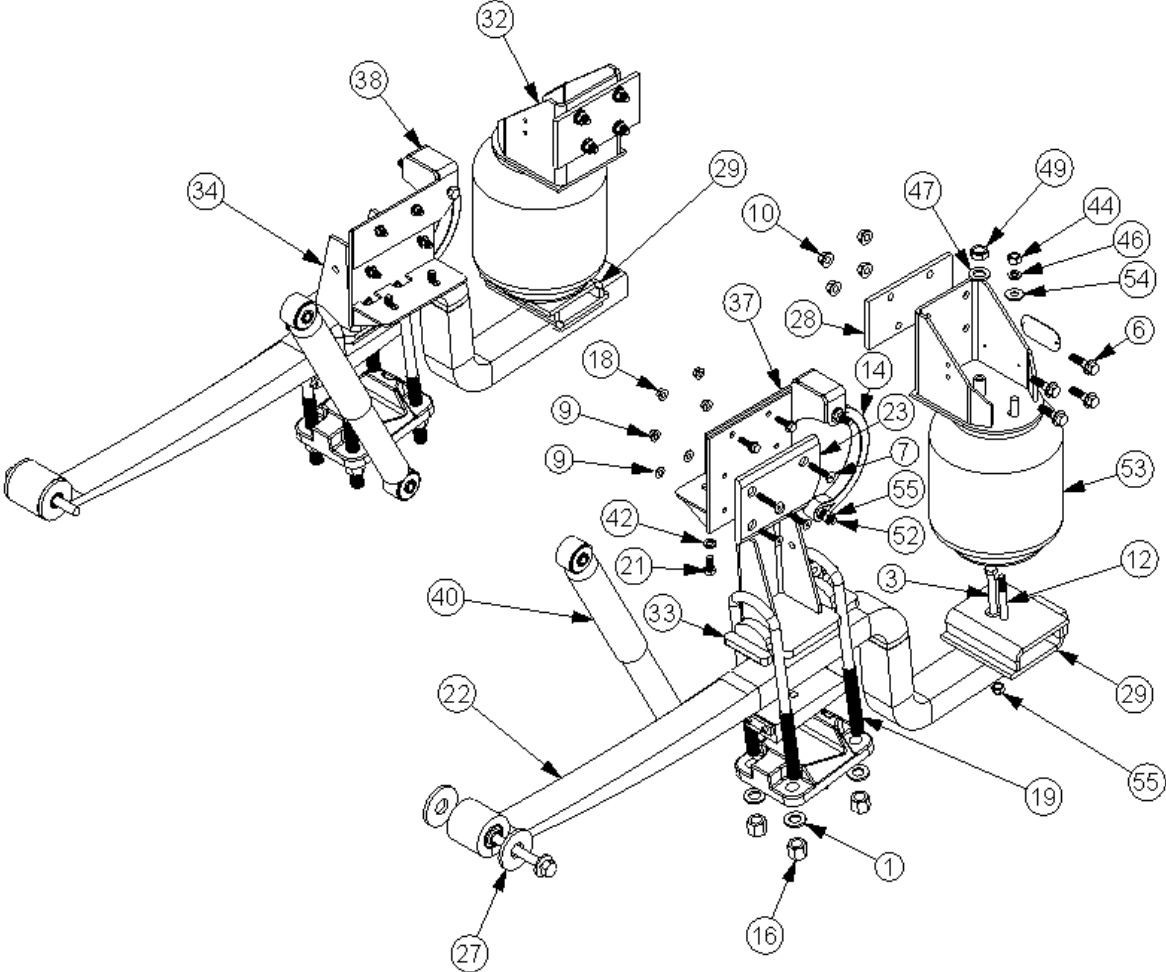

PARTS LIST

ITEM #	QTY.	PART NO.	DESCRIPTION
1	8	103003	HFW 3/4
2	2	118	FW 1/2 .531 X 1.062 X .095
3	2	127	HHB 1/2-20x3.50 Gr.8 ZN
4	2	188	Pop Rivet 1/8" dia. x .525" long
5	1	2617	Plate-Serial No.
6	8	276	FHB 1/2-13x1.75 GR.8
7	4	298	SFCS 3/8-24 x 2.00 Gr.8
8	4	302	FHB 3/8-16 x 1.25" Gr. 8 ZN
9	8	304	LFN 3/8-24, Gr. F, ZINC
10	8	308	LFN 1/2-13, GR. G ZN
11	4	4356	SFCS 3/8-24 x 1.5 GR.8 PH
12	2	5559	HHB 1/2-13 x 4.50, Gr. 5, ZN
*13	2	5608	HEIGHT CONTROL VALVE
14	2	6249	REBOUND STRAP 9.80x1.00
15	2	6573	Spacer, Rebound Strap (2.937)
16	8	6868	HN 3/4-16 Highnut Gr.C
*17	4	702016-02	Elbow swivel 1/4Tx1/8MPT
18	4	702605-01	LFN 3/8-16, Gr. G, ZN
19	4	705059-01	U-Bolt, Axle Seat
20	4	705912-01	Tube, Shock Bushing
21	4	708159-01	HHB M12-1.75x110 CL10.9 PH
22	2	708395-01	Asy, Spring Beam
23	1	708578-01	Wear Pad, LH
24	1	708578-02	Wear Pad, RH
**26	1	708580-01	Heat Shield, Flexible
27	4	708758-01	Disc, Pivot Wear
28	2	708778-01	Backing Plate
1	8	103003	HFW 3/4

ITEM #	QTY.	PART NO.	DESCRIPTION
29	2	709094-01	ASY, LOWER AIR SPRING PAD
30	4	709286-01	SHOCK BUSHING 3/4OD X 5/8ID
31	1	709785-01	Upper Air Spring Pad Asy, LH
32	1	709785-02	Upper Air Spring Pad Asy, RH
33	1	709891-01	WEAR TOWER ASY LH
34	1	709891-02	WEAR TOWER ASY RH
35	1	709892-01	Asy, Axle Wedge LH
36	1	709892-02	Asy, Axle Wedge RH
37	1	709893-01	BACKING PLATE ASY LH
38	1	709893-02	BACKING PLATE ASY RH
*39	2	709953-01	HCV LINK NON-ADJ 9.75"
40	2	709984-01	Shock Absorber
41	2	7132	Sleeve, Rebound Strap (1.20)
42	4	8103323	SLW 1/2" .523 x .873 x .134, PL
*43	4	8120375	Nut 1/4-20, Gr. 5, ZP
44	2	8120378	N 1/2-13, Gr. 5, ZP
*45	4	8120380	SLW 1/4"
46	2	8120384	SLW 1/2 .523x.873x.135 ZN
47	2	8131017	FW 3/4" .812 x 1.469 x .134, ZP
*48	4	8180020	HHB 1/4-20 x 3/4, Gr. 5, ZN
49	2	8219758	JN 3/4-16, Gr. 5, ZP
50	2	8274318	HHB 1/2-20 x 5, GR.8
*51	4	8454750	LN 1/4-28 GR 5
52	2	8455030	HHB 1/2-20 x 2.75, Gr. 8
53	2	8609	Air Spring Assembly
54	2	89415543	FW 1/2 .531x1.25x.100 ZN
55	6	89422302	LN 1/2-20, Gr. C

* K709008

** Not shown

PARTS LIST

INSPECTION & MAINTENANCE

Perform a thorough visual inspection of the suspension to ensure proper assembly and to identify broken parts and loose fasteners each time the vehicle suspension is serviced. Do the following during an inspection.

- **Fasteners** - Using a calibrated torque wrench check that all the fasteners are tightened to the proper torque.
- **Wear and Damage** - Inspect components of the suspension for wear and damage. Look for bent or broken components. Replace all worn or damaged components.
- **Operation** - Check that all components move freely through the complete turning arc.



CAUTION: Reyco Granning® recommends replacing any damaged or out-of-specification components. Reconditioning or field repairs of major rear suspension components is not allowed.

Note: Refer to Section 1 for identification of components.

NOTE: Reyco Granning® recommends the use of a maintenance pit or full vehicle lift during the inspection of components.



WARNING: Never work under a vehicle supported by only a jack. Jacks can slip or fall over and cause serious personal injury. Always use safety stands.

Height Control Valve Inspection and Adjusting Suspension Ride Height

The height control valve and linkage should be checked regularly for proper clearance, operation and adjustment. The ride height of the rear suspension is the distance from the bottom of the chassis frame rail to the center of the axle. Properly adjusted ride height results in correct suspension travel and alignment. The ride height should not be adjusted to adjust chassis rake angle.

To check ride height

1. Park the vehicle on a level surface.
2. If the suspension is equipped with kneelers lower the suspension.
3. Re-inflate the air suspension. Allow the Suspension to settle.
4. Set the parking brake and block the drive wheels to prevent vehicle movement.
5. make sure nothing is interfering with the travel of the height control valve arms,
6. Measure the distance from bottom of chassis to center of axle on each side. The ride height should be 11.88 inches.

To adjust ride height

1. Loosen nut on side of HCV arm,
2. Slide short arm up or down as needed,
3. Torque nut to 30 to 45 in-lbs,
4. Repeat steps 1 thru 3 on other side,

INSPECTION & MAINTENANCE

5. Recheck ride height as stated in previous section.

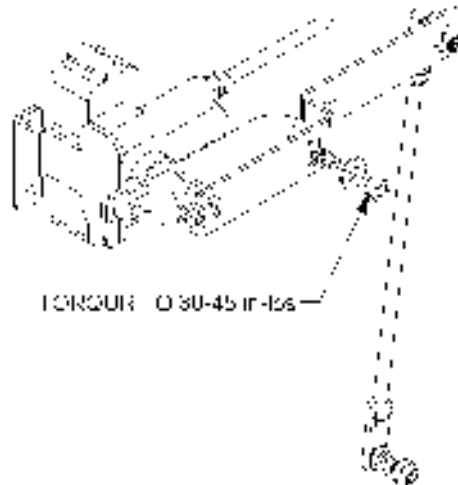

Figure 2: Height Control Valve

TORQUE SPECIFICATIONS

Most threaded fasteners are covered by specifications that define required mechanical properties, such as tensile strength, yield strength, proof load, and hardness. These specifications are carefully considered in initial selection of fasteners for a given application. To assure continued satisfactory vehicle performance, replacement fasteners used should be of the correct strength, as well as the correct nominal diameter, thread pitch, length, and finish.



Figure 5: Grade Markings on Bolts



Grade	Lock Nut Grade B, F	Lock Nut: Grade C, G
Identification	 3 Dots	 6 Dots

Figure 6: Grade Markings on Lock Nuts

INSPECTION & MAINTENANCE

Reyco Granning Recommended Torque Specifications

Item	Assembly	Fastener	Torque (Ft/lbs)
1	Spring Beam Pivot Connection	OEM (HEX FLANGE HEAD, M20X1.50X167.00)	480 ft-lbs
2	Upper Air Spring Pad Mount (to Frame)	FHB 1/2-13 X 1.75 GR.8 ZN	80 ft-lbs
3	Lower Air Spring Assembly Mount (to Beam)	HHB 1/2-13 x 3, Gr. 8 ZN	90 ft-lbs
4	Stud Nut (Air Spring)	N 1/2-13 GR 5 ZP	35 ft-lbs
5	Air Port Nut (Air Spring)	JN 3/4-16 GR 5 ZP	35 ft-lbs
6	Backing Plate to Chassis	FHB 3/8-16 X 1.25 GR8 ZINC	35 ft-lbs
7	Wear Pad to Backing Plate	SFCS 3/8-24 x 2.0 Gr. 8	100 in-lbs
8	Rebound Strap Upper & Lower Mount	1/2-20 Grade G	90 ft-lbs
9	HCV bolts	HHB 1/4-20 X .75 GR 5 ZN	8 ft-lbs
10	U-Bolt Nuts	U-BOLT, AXLE SEAT	250 ft-lbs
11	Shock Bolts (Refer to Vehicle Owners Manual)	See Vehicle Owners	**See Vehicle Owners
12	Wheels (Refer to Vehicle Owners Manual)	See Vehicle Owners	**See Vehicle Owners

****Follow procedures and torques listed in Dodge Maintenance Manual**

Note: Torque values listed above apply only if Reyco Granning supplied fasteners are used. For information regarding component replacement or technical service call 1-800-753-0500

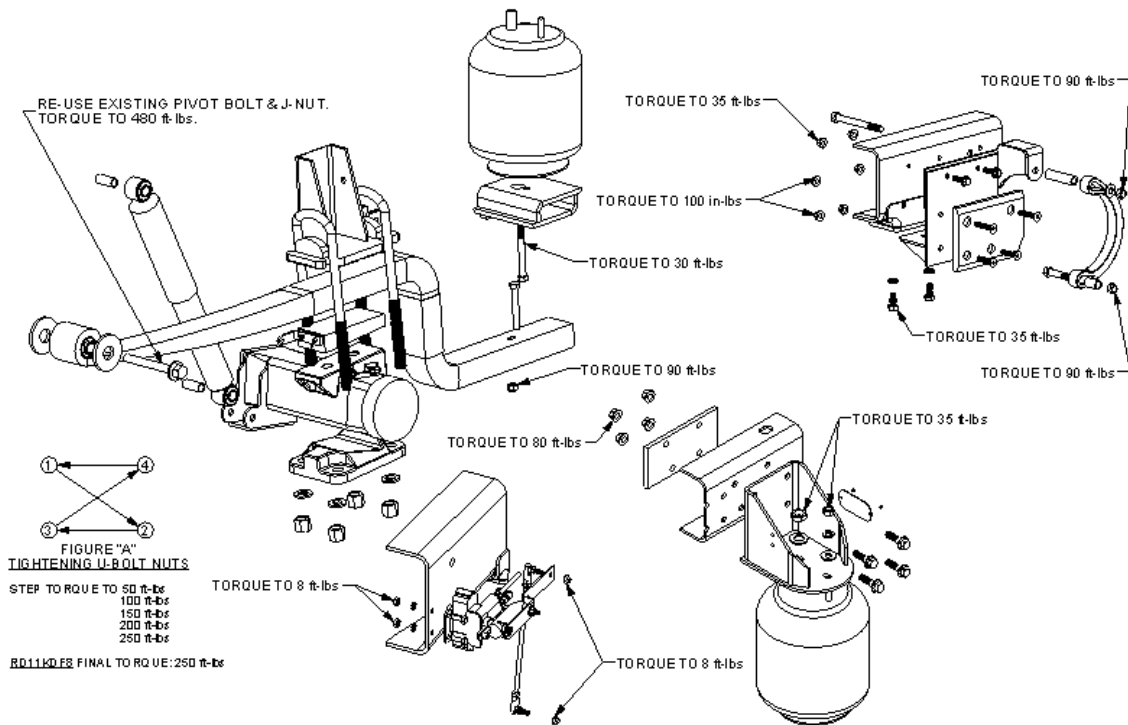

INSPECTION & MAINTENANCE

Maintenance Schedule

GENERAL MAINTENANCE	SERVICE TO BE PERFORMED	MILEAGE IN THOUSANDS							
		12	24	36	48	60	72	84	96
Spring Beam Pivot Connection	Check bolt torque.	X			X				X ¹
	Inspect for contact between Spring Beam and Hanger.	X	X	X	X	X	X	X	X ¹
	Inspect for bushing wear.	X	X	X	X	X	X	X	X ¹
Air Springs	Inspect for proper clearance (1" minimum all around).	X							
	Check upper mount nut and lower mount bolt torque.	X							
	Inspect for signs of chafing or wear.	X	X	X	X	X	X	X	X ¹
	Check for air line fitting torque.	X							
	Inspect for air leaks using soapy water solution.	X							
Height Control Valve Linkage	Inspect for signs of bending, binding, or slippage.	X	X	X	X	X	X	X	X ¹
Air Fittings and Air Lines	Inspect for air leaks using soapy water solution	X							
	Inspect for signs of chafing, cracking, or wear	X	X	X	X	X	X	X	X
Shock Absorbers	Check stud mount and lock nut torque.	X							
	Inspect shocks for signs of fluid leak, broken eye ends, loose fasteners, or worn bushings.	X	X	X	X	X	X	X	X ¹
Axle Connection	Check "U"-bolt nut torque	X	X	X	X	X	X	X	X
Wheels ²	Check lug nut torque ³	X	X	X	X	X	X	X	X
Air Compressor	Check air compressor compartment or enclosure for proper airflow and venting.	X	X	X	X	X	X	X	X
Rear Alignment	Inspect (after first 1000-3000 miles)		X		X		X		X ¹
Air Fittings and Air Lines	Inspect for air leaks using soapy water solution.	X							
	Inspect for signs of chafing, cracking, or wear.	X	X	X	X	X	X	X	X ¹

¹ Continue to perform specified maintenance every 12,000 miles.

² See your vehicle's owner's manual for instructions regarding the maintenance of wheels and tires.

³ Wheel lug nuts must be retightened to proper torque specifications as per the vehicle or chassis manufacturer's Owner Guide.

TROUBLE SHOOTING

SYMPTOMS	POSSIBLE CAUSES	REMEDIES
Tires wear out quickly or have uneven tire tread wear. Note: Wear pattern will indicate possible cause(s). Consult tire manufacturer for guidance.	<ol style="list-style-type: none"> 1) Tires have incorrect pressure. 2) Tires out of balance. 3) Incorrect ride height. 4) Incorrect rear axle alignment. 5) Improper (mismatched) tires and wheels. 	<ol style="list-style-type: none"> 1) Put specified air pressure in tires. 2) Balance or replace tires. 3) Adjust ride height to specified setting. 4) Align rear axle to specified thrust angle. 5) Install correct tire and wheel combination.
Vehicle rolls side to side excessively.	<ol style="list-style-type: none"> 1) Shock absorbers worn. 2) Shock eye bushings worn. 3) Axle U-bolts are loose 4) Loose or worn Spring Beam Pivot connection(s). 5) Loose or worn Spring Beam Pivot bushing(s). 6) Check for air leak including the height control valve. 	<ol style="list-style-type: none"> 1) Replace shock absorbers as needed. 2) Check and replace as needed.. 3) Tighten (see previous torque chart) or replace as required 4) Tighten (see previous torque chart) or replace as required 5) Replace as required 6) Check height control valve and replace as required.
Vehicle ride is too harsh and/or suspension contacts stops excessively.	<ol style="list-style-type: none"> 1) Shock absorbers worn. 2) Incorrect ride height. 3) Vehicle overloaded. 4) Air spring supply lines leaking or obstructed. 5) Vehicle system air pressure below specification. 6) Jounce bumper in air spring worn or broken. 7) Air Suspension not turned on. 8) Defective Height Control Valve(s) 9) Height Control Linkage disconnected or damaged 	<ol style="list-style-type: none"> 1) Replace shock absorbers as needed. 2) Adjust ride height to specified setting. 3) Check wheel loads and correct as needed. 4) Check air line connections and remove obstructions. 5) Check air pressure and correct as needed. 6) Check and replace air spring as required. 7) Turn on air suspension. 8) Replace height control valve as required. 9) Reattach or replace as required.
Vehicle ride is too soft.	<ol style="list-style-type: none"> 1) Shock absorbers worn. 2) Incorrect ride height. 	<ol style="list-style-type: none"> 1) Replace shock absorbers as needed. 2) Adjust ride height to specified setting.

TROUBLE SHOOTING

SYMPTOMS	POSSIBLE CAUSES	REMEDIES
Suspension does not maintain ride height.	1) Air leak. 2) Internal leak in height control valve. 3) Height control valve linkage loose. 4) Air spring chafed or worn.	1) Check connections with soapy water solution and repair or replace as needed. 2) Check height control valve and replace as required. 3) Check and tighten linkage as needed. 4) Check air spring and replace as needed.
Air compressor runs excessively	Air leak. Internal air leak in height control valve. Moisture ejector valve stuck open. Check valve installed incorrectly. Dump valve(s), or “kneeler(s)”, leaking. Height Control Valve stuck in the exhaust position.	Inspect all air lines, fittings, and air springs with a soapy water solution. Repair, retighten, or replace as required. Note: Plastic air lines must be cut square. See Air Control System Parts List (General Notes) for additional notes. Insert exhaust tube into a cup of water and examine for bubbles. This will show evidence of both inlet and exhaust valve leaks. Replace components. Check and replace if necessary. Arrow should point away from the air compressor head. Correct if necessary. Check and replace if necessary. Locate obstruction and remove or relocate interference.
Air compressor will not start	Inline fuse burnt or circuit breaker tripped. Air compressor motor burnt out. Disconnected or broken wire. Ignition switch and/or suspension power switch not on.	Replace or reset. Inspect and replace as required. Inspect and correct or replace if necessary. Turn on ignition switch and/or suspension switch.

-4 SYSTEM 9930 AIR SYSTEM WITH KNEELER VALVES

Item #	Part #	Description	Item #	Part #	Description
1	702603-01	UNION TEE 1/4T X 1/4T X 1/4T	22	5008	CONTROL PANEL-POWER/KNLR (RD)
2	0416	CONNECTOR - 1/4T X 1/8MPT	23	100702-P1	HHB 1/4-20 X 1 GR 8 ZN
3	0599	CONNECTOR - 1/4T X 1/4FPT	24	100703-P1	LN 1/4-20 STOVER GRC PLATED
4	4017	CHECK VALVE (R-SER COMPRESSOR)	25	700726-01	HWHMS 10-32x1.00 STEEL ZN
5	707413-01	VALVE, KNEELER 12VDC 3-WAY	28	308	LFN 1/2-13 GR G ZINC
6	6115	MALE CON. (3/16HBx1/8MPT)	29	307	FHB 1/2-13 X 1 1/2 GR 8 ZINC
7	701799-01	CV TUBING 3/16IDx1/4ODx3.00	30	309	FHB 1/2-13 X 1.25 GR 8 ZINC
8	5188	COMPRESSOR - 1/3 HP 12VDC	31	702600-01	ELBOW 90 1/4T X 1/4MPT
9	0428	CONNECTOR - 1/4T X 1/4MPT	32	8892	PRESSURE SWITCH
10	K709031	KIT, HCV, RD975D-AB, -4, -5	33	708262-01	Split Convolved sleeving 3/8"
11	0437	ELBOW 45-ST 1/4MPTx1/4FPT	34	0141	PLUG- 1/4" PT SQUARE HEAD
12	8722	3/16 ID X 1/4 OD X 12" CV TUBE	35	704916-01	HEATED AUTO DRAIN VLV, BRK ACT
14	5392	VIBRATION ISOLATOR	36	8614	TANK, AIR RESERVOIR
15	8120214	SLW 5/16 .328x.586x.088 ZP	37	8625	BRACKET, AIR TANK MOUNT
16	8120393	FW 5/16 .344x.688x.065 ZP	38	8706	SOLENOID, COLE HERSEE #24059
17	8870	FRAME BRKT. KNEELER VALVE	39	8721	CIRCUIT BREAKER 40 AMP (SEALED)
18	89411893	LN 10-32 GR 5 CP	40	703683-01	WIRING HARNESS W/ RELAY
19	89429048	N 5/16-18 GR 8 ZP	--	D705274	Drawing, Air Kit Asy
20	4981	SWITCH-TOGGLE 12 VOLT/35 AMP	--	D9930	DWG, AIR CNTL KIT
21	5157	SWITCH-TOGGLE (RED LIGHT)			

1. Airline tubing should be 1/4" D.O.T. plastic airline tubing.
2. The tubing ends must be cut straight and insert the full depth into the fittings otherwise leaks will result. Check all connections for air leaks.
3. Protective airline loom is recommended.

-5 SYSTEM 9932 AIR SYSTEM WITHOUT KNEELER VALVES

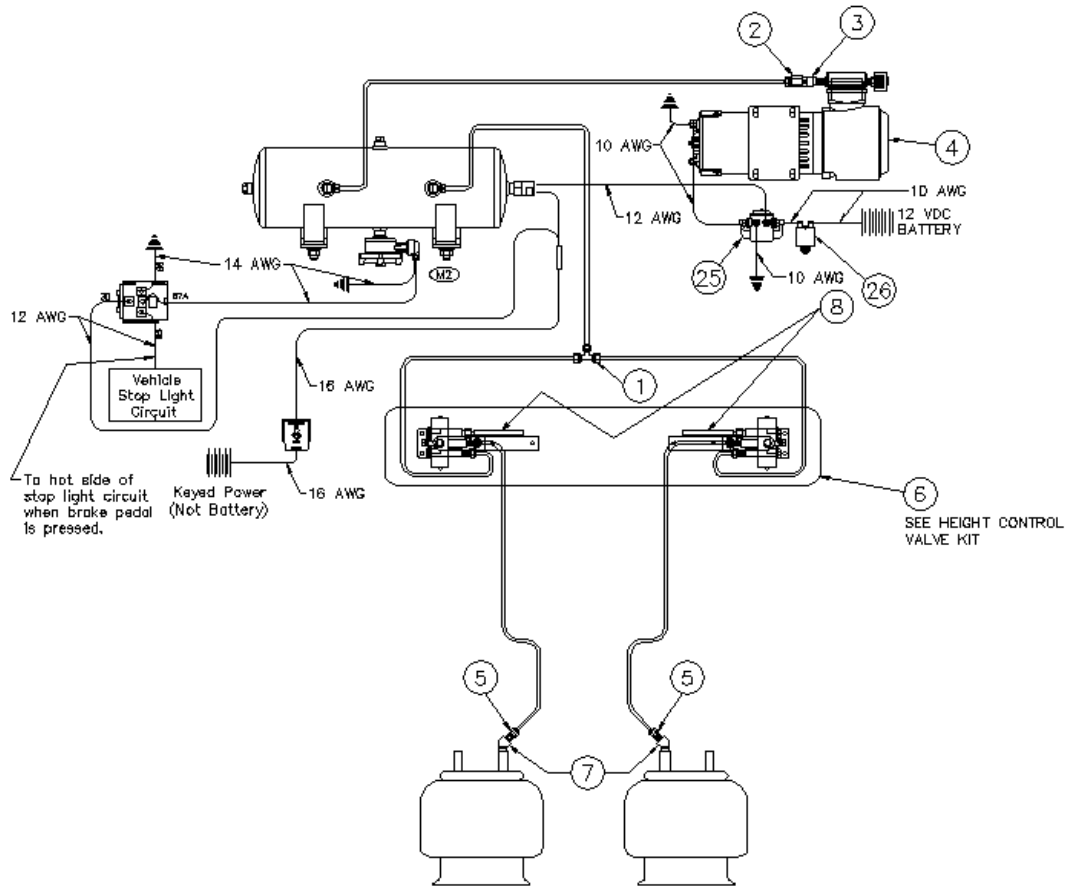

SWITCH PANEL ASSEMBLY

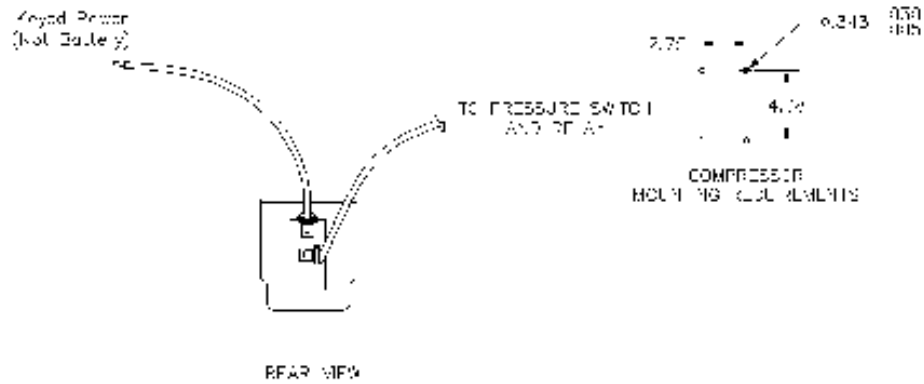
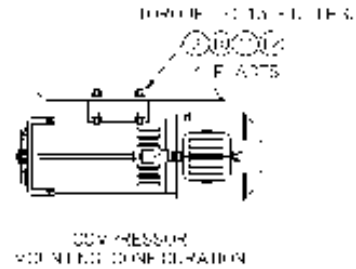
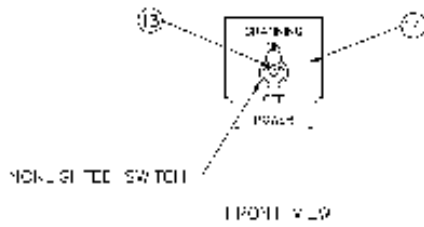

-5 SYSTEM 9932 AIR SYSTEM WITHOUT KNEELER VALVES

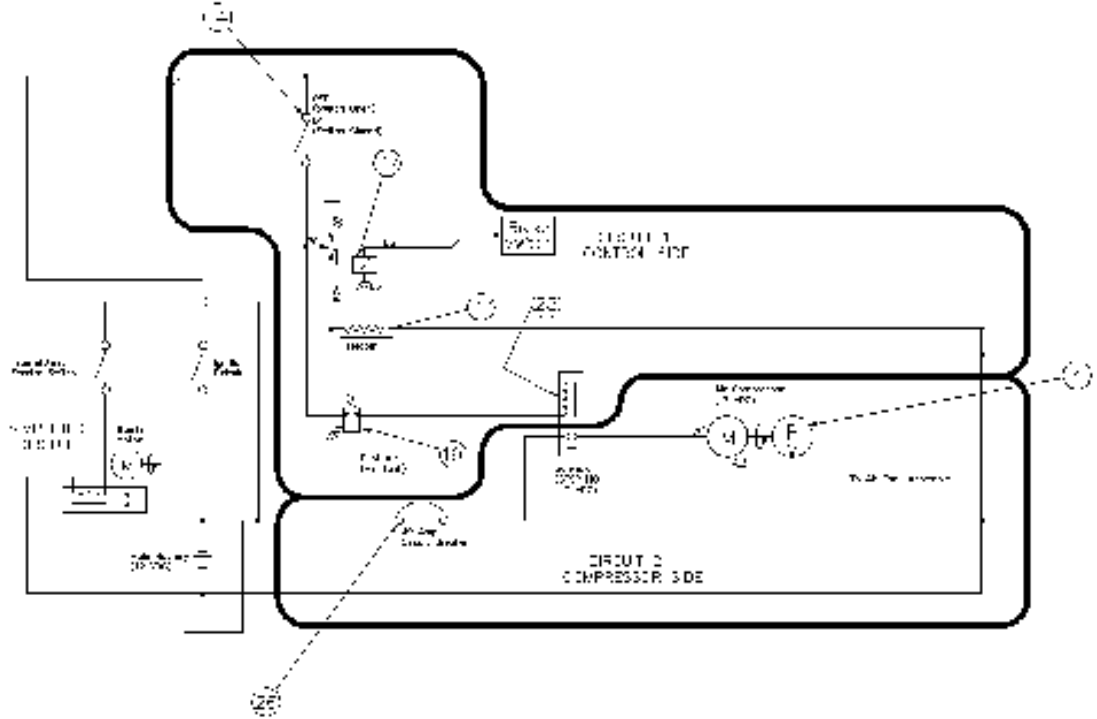
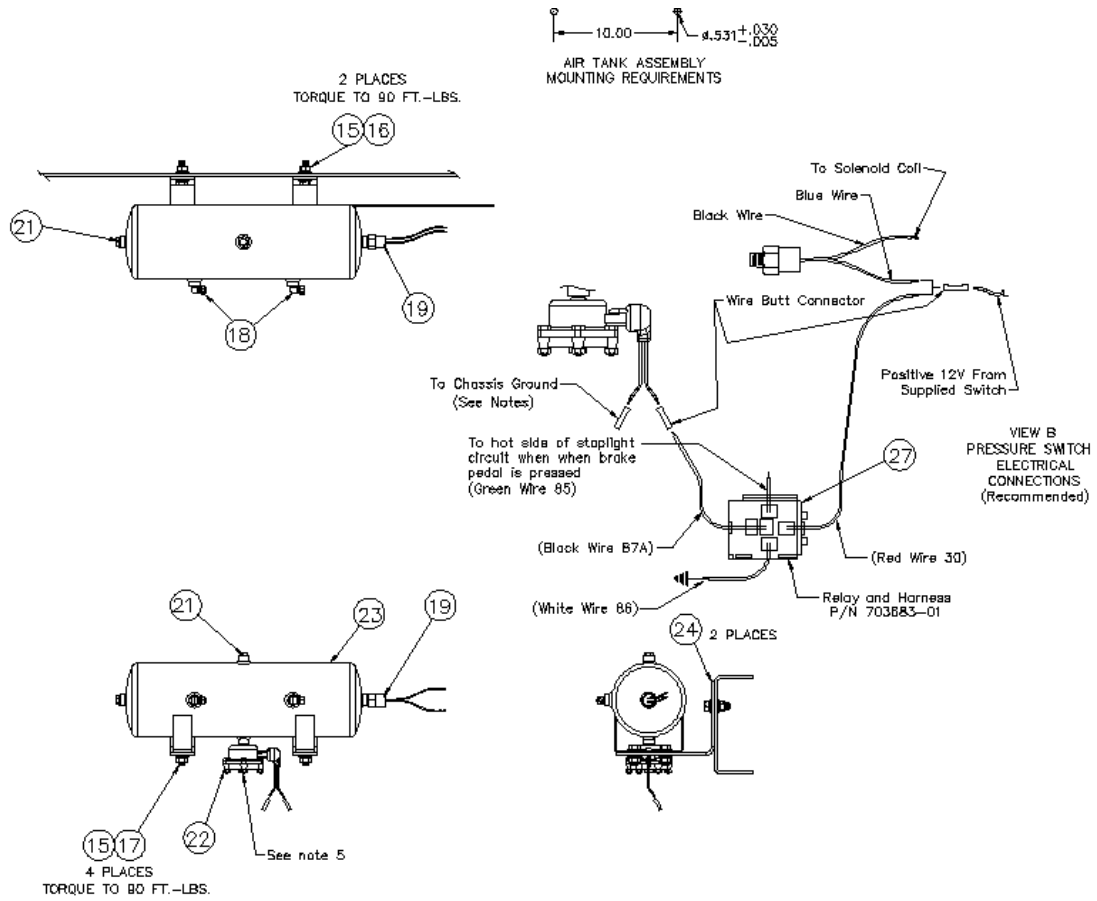

-5 SYSTEM 9932 AIR SYSTEM WITHOUT KNEELER VALVES

Item #	Part #	Description	Item #	Part #	Description
1	702603-01	UNION TEE 1/4T X 1/4T X 1/4T	16	307	FHB 1/2-13 X 1 1/2 GR 8 ZINC
2	0599	CONNECTOR - 1/4T X 1/4FPT	17	309	FHB 1/2-13 X 1.25 GR 8 ZINC
3	4017	CHECK VALVE (R-SER COMPRESSOR)	18	702600-01	ELBOW 90 1/4T X 1/4MPT
4	5188	COMPRESSOR - 1/3 HP 12VDC	19	8892	PRESSURE SWITCH
5	0428	CONNECTOR - 1/4T X 1/4MPT	20	708262-01	Split Convolute sleeveing 3/8"
6	K709031	KIT, HCV, RD975D-AB, -4, -5	21	0141	PLUG- 1/4" PT SQUARE HEAD
7	0437	ELBOW 45-ST 1/4MPTx1/4FPT	22	704916-01	HEATED AUTO DRAIN VLV, BRK ACT
8	8722	3/16 ID X 1/4 OD X 12" CV TUBE	23	8614	TANK, AIR RESERVOIR
9	5392	VIBRATION ISOLATOR	24	8625	BRACKET, AIR TANK MOUNT
10	8120214	SLW 5/16 .328x.586x.088 ZP	25	8706	SOLENOID, COLE HERSEE #24059
11	8120393	FW 5/16 .344x.688x.065 ZP	26	8721	CIRCUIT BREAKER 40 AMP (SEALED)
12	89429048	N 5/16-18 GR 8 ZP	27	703683-01	WIRING HARNESS W/ RELAY
13	4981	SWITCH-TOGGLE 12 VOLT/35 AMP	--	D705274	Drawing, Air Kit Asy
14	4910	CONTROL PANEL (RD/RT/RFT)	--	D9932	DWG, AIR CNTRL-DUAL HCV
15	308	LFN 1/2-13 GR G ZINC			

1. Airline tubing should be 1/4" D.O.T. plastic airline tubing.
2. The tubing ends must be cut straight and insert the full depth into the fittings otherwise leaks will result. Check all connections for air leaks.
3. Protective airline loom is recommended.

-AB SYSTEM K706859 AIR SYSTEM WITH KNEELER VALVES, PING TANKS, & WIRE HARNESS

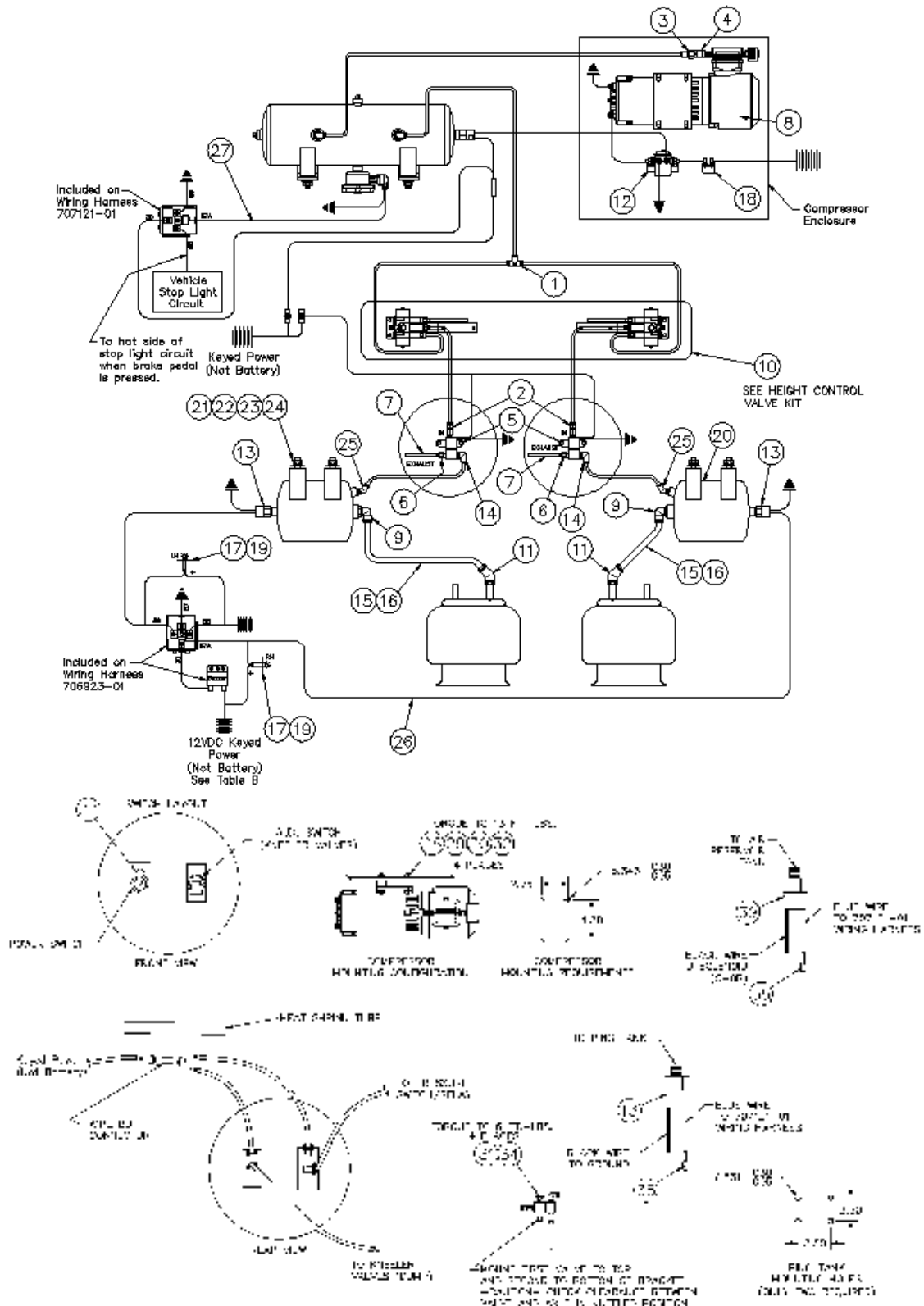

-AB SYSTEM K706859 AIR SYSTEM WITH KNEELER VALVES, PING TANKS, & WIRE HARNESS

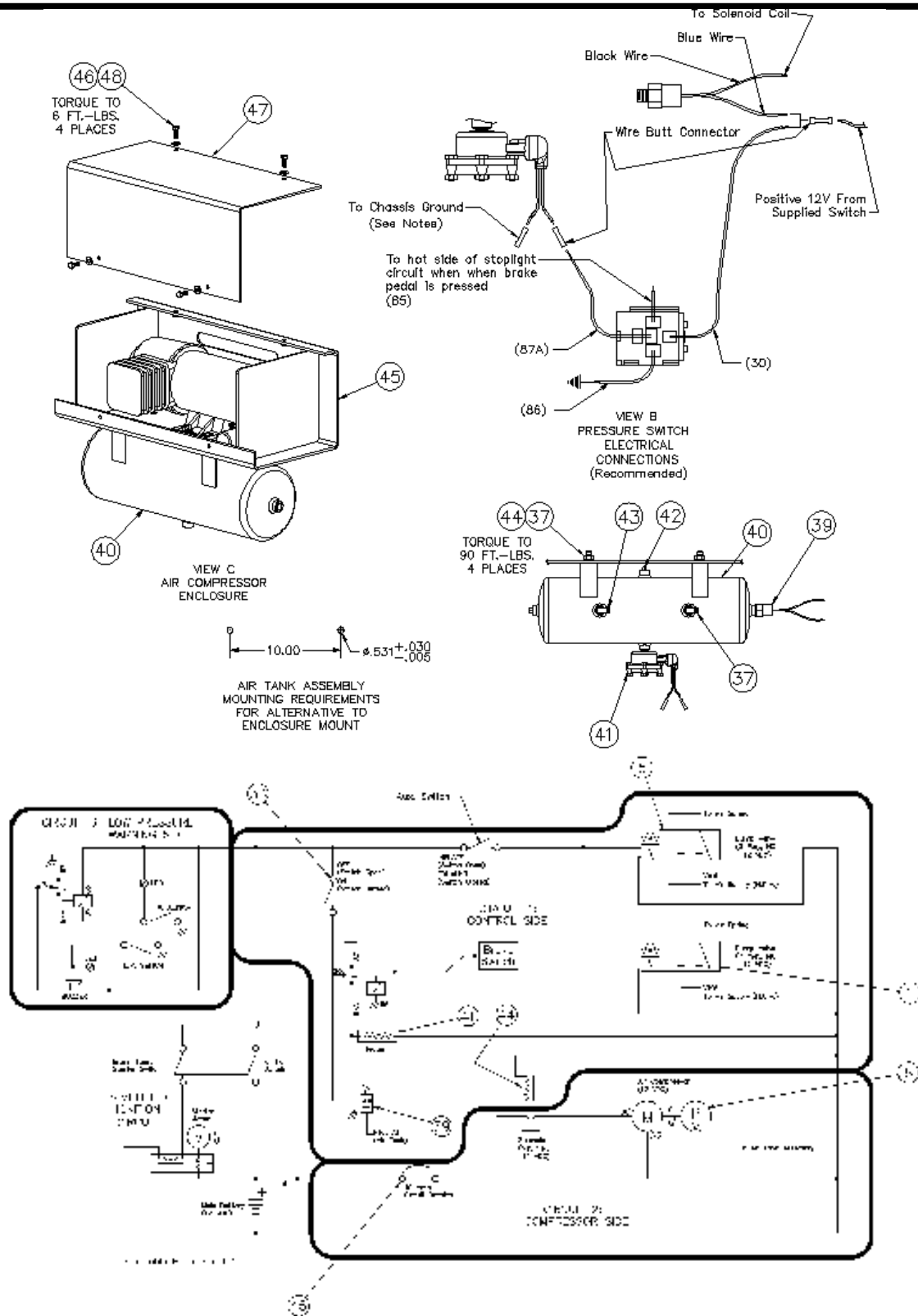

-AB SYSTEM K706859 AIR SYSTEM WITH KNEELER VALVES, PING TANKS, & WIRE HARNESS

Item #	Part #	Description
* 1	KV2T07-00	Tee, Union, 1/4 T x 1/4 T x 1/4 T
*** 2	KV2H07-34S	Connector, 1/4 T x 1/8 MPT
* 3	KV2F07-35	Connector, Female, 1/4 T x 1/4 FPT
4	4017	CHECK VALVE (R-SER COMPRESSOR)
5	707413-01	VALVE, KNEELER 12VDC 3-WAY
6	6115	MALE CON. (3/16HBx1/8MPT)
7	701799-01	CV TUBING 3/16IDx1/4ODx3.00
8	5188	COMPRESSOR - 1/3 HP 12VDC
* 9	KV2L13-37S	ELBOW, 90 1/2T X 1/2MPT
10	K709031	KIT, HCV, RD975D-AB, -4, -5
* 11	KV2K13-35S	ELBOW, 45 1/2T X 1/4MPT
12	8706	SOLENOID, COLE HERSEE #24059
13	7457	LOW PRESSURE SWITCH (5 PSI)
* 14	KV2L07-34S	ELBOW, 90 1/4T X 1/8MPT
15	6247	TUBING-1/2ODx.062 WALL THK AB
16	708263-01	SPLIT CONVOLUTED SLEEVING 5/8"
17	706887-01	LED, RED, 12V
18	8721	CIRCUIT BREAKER 40 AMP (SEALED)
19	706959-01	PALNUT, 5/16"
20	8619	TANK, AIR "PING", 200 CU. IN.
21	8120371	N 1/2-20 GR 5 ZP
22	8120384	SLW 1/2 .523x.873x.135 ZP
23	8455028	HHB 1/2-20 X 1 1/2, GR.8, ZN
24	89415543	FW 1/2 .531x1.250x.100 ZP

Item #	Part #	Description
* 25	KV2K07-35S	ELBOW, 45 1/4T X 1/4MPT
26	706923-01	WIRING HARNESS, R-SERIES
27	707121-01	WIRING HARNESS, R-SERIES
28	5392	VIBRATION ISOLATOR
29	8120214	SLW 5/16 .328x.586x.088 ZP
30	8120393	FW 5/16 .344x.688x.065 ZP
31	89411893	LN 10-32 GR 5 CP
32	89429048	N 5/16-18 GR 8 ZP
33	4981	SWITCH-TOGGLE 12 VOLT/35 AMP
34	700726-01	HWHMS 10-32x1.00 STEEL ZN
35	400056-P1	SLIDE
37	309	FHB 1/2-13 X 1.25 GR 8 ZINC
39	8892	PRESSURE SWITCH
40	8614	TANK, AIR RESERVOIR
41	704916-01	HEATED AUTO DRAIN VLV, BRK ACT
* 42	KV-109B	PLUG, SQUARE HD 1/4MPT
* 43	KV2L07-35S	ELBOW, 90 1/4T X 1/4MPT
44	308	LFN 1/2-13 GR G ZINC
** 45	707356-01	WELDMENT, COMP. ENCLOSURE
** 46	100679-P1	HHB 1/4-20 X 3/4, GR.8, ZN
** 47	707030-01	COVER, COMPRESSOR ENCLOSURE
** 48	8120392	FW 1/4 .281x.625x.065 ZP
--	D706859	DWG, AIR CONTROL KIT W/ HARNESS
--	K706855	KIT, LIFT CONTROL FITTINGS

- * K706855 KIT, LIFT CONTROL FITTINGS
- ** K707294 KIT, COMPRESSOR ENCLOSURE
- *** K706858 KIT, HCV, RD1350F-AB

1. Airline tubing should be 1/4" D.O.T. plastic airline tubing.
2. The tubing ends must be cut straight and insert the full depth into the fittings otherwise leaks will result. Check all connections for air leaks.
3. Protective airline loom is recommended.

-QR SYSTEM K709308 QUICK RECOVERY AIR SYSTEM

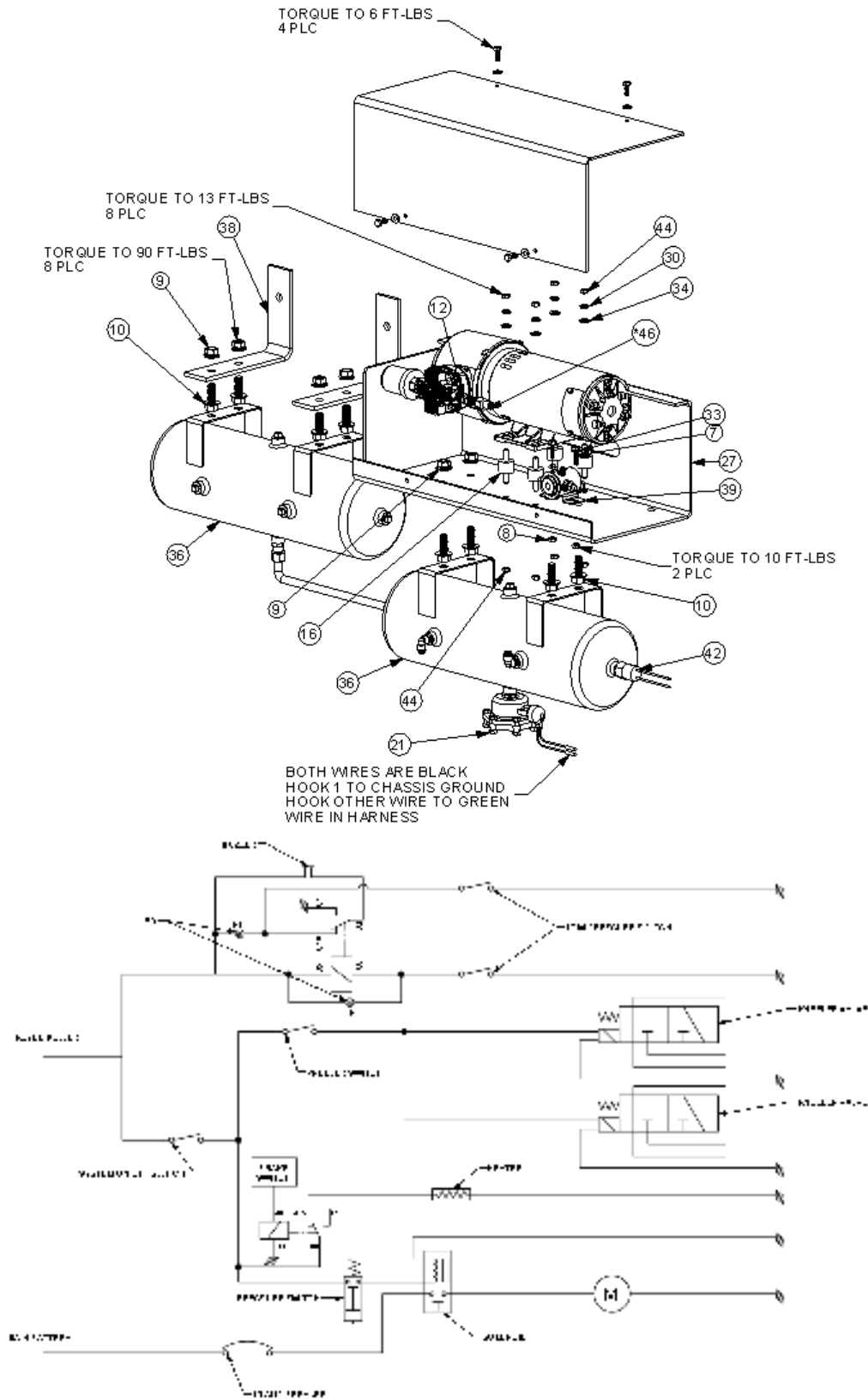

-QR SYSTEM K709308 QUICK RECOVERY AIR SYSTEM

ITEM	PART #	DESCRIPTION	ITEM	PART #	DESCRIPTION
1	123	REDUCER - 1/2MPT-1/4FPT	26	707121-01	WIRING HARNESS UNDER HOOD
*2	141	PIPE PLUG - 1/2NPT	27	707294	WELDMENT, COMPONENT ENCLOSURE
3	416	CONNECTOR - 1/4T X 1/8MPT	28	707413-01	VALVE, KNEELER 12VDC 3-WAY
4	428	CONNECTOR - 1/4T X 1/4MPT	29	7457	LOW PRESSURE SWITCH (5 PSI)
5	441	TEE-ST 1/4 FPT X 1/4 MPT	30	8120214	SLW 5/16"
6	627	CONNECTOR - 1/2T X 1/4MPT	31	8120371	N 1/2-20 GR 5 ZN
7	100702-P1	HHB 1/4-20 X 1, GR. 8, ZN	32	8120384	SLW 1/2 .523x.873x.135 ZN
8	100703-P1	LN 1/4-20 STOVER, GR. 8, ZN	33	8120392	FW 1/4 .281 x .625 x .065, ZN
9	308	LFN 1/2-13, GR. G ZN	34	8120393	FW 5/16 .344x.68x.065 ZN
10	309	FHB 1/2-13 x 1 1/4, GR. 8, ZN	35	8455028	HHB 1/2-20 X 1 1/2, GR.8, ZN
11	400056-P1	TERMINAL, MALE SPADE 22-18AWG	36	8614	AIR TANK - 500CI 6" DIA
12	4017	CHECK VALVE	37	8619	AIR TANK, PING 212 CI
13	4981	SWITCH, TOGGLE	38	8625	BRACKET, AIR TANK MOUNT
14	5157	TOGGLE SWITCH, RED LIGHT	39	8706	SOLENOID
15	5188	COMPRESSOR - 1/3 HP 12VDC	40	8721	CIRCUIT BREAKER, 40A SEALED
16	5392	VIBRATION ISOLATOR	41	8870	FRAME BRKT, KNEELER VALVE
17	5608	HEIGHT CONTROL VALVE	42	8892	PRESSURE SWITCH 95-115 PSI
18	6115	MALE CON.(3/16HBx1/8MPT)	43	89411893	LN 10-32 GR 5 CP
19	700726-01	HWHMS 10-32x1.00 STEEL ZN	44	89415543	FW 1/2 .531x1.25x.100 ZN
20	701799-01	CV TUBING 3/16IDx1/4ODx3.00	45	89429048	N 5/16-18 GR 8 ZN
21	704916-01	HEATED AUTO DRAIN VLV, BRK ACT	*46	KV2F07-35	FEMALE CONNECTOR, 1/4T X 1/4FPT
22	706887-01	LED, RED, 12V	*47	KV2K07-35S	45DEG MALE ELBOW, 1/4T X 1/4MPT
23	706923-01	WIRING HARNESS IN CAB	*48	KV2L07-34S	90DEG MALE ELBOW 1/4T X 1/8MPT
24	706959-01	PALNUT, 5/16"	*49	KV2L07-35S	90DEG MALE ELBOW, 1/4T X 1/4MPT
*25	707069-01	CONNECTOR, 1/4T x 1/8MPT	*50	KV2T07-00	TEE, UNION, 1/4T X 1/4T X 1/4T

- * K706855 KIT, LIFT CONTROL FITTINGS
- ** K707294 KIT, COMPRESSOR ENCLOSURE
- *** K706858 KIT, HCV, RD1350F-AB

1. Airline tubing should be 1/4" D.O.T. plastic airline tubing.
2. The tubing ends must be cut straight and insert the full depth into the fittings otherwise leaks will result. Check all connections for air leaks.
3. Protective airline loom is recommended.

9905 AUXILIARY PING TANK KIT

Item	Part No.	Description	Item	Part No.	Description
1	0428	Connector 1/4T x 1/4MPT	7	8120371	N 1/2-20 Gr. 5 ZP
2	0627	Connector 1/2T x 1/4MPT	8	8120384	SLW 1/2 .523 x .873 x .135
3	0635	Connector 1/2T x 1/2MPT	9	8455028	HHB 1/2-20 x 1 1/2, Gr. 8
4	0636	Plug 1/4MPT Countersunk	10	8619	Tank, Air "Ping" 200 cu. in.
5	6247	Tubing 1/2 O.D.	11	89415543	FW 1/2 .531 x 1.25 x .100
6	6248	Loom, Braided Nonmetallic	12	0437	Elbow 45 deg. 1/4MPTx1/4FPT

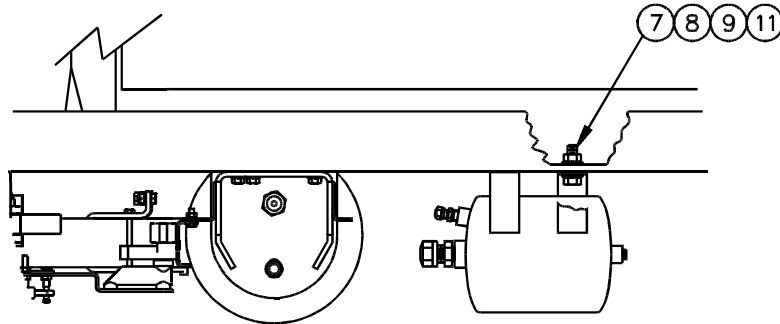

Sample tank mounting

Valves existing on vehicle

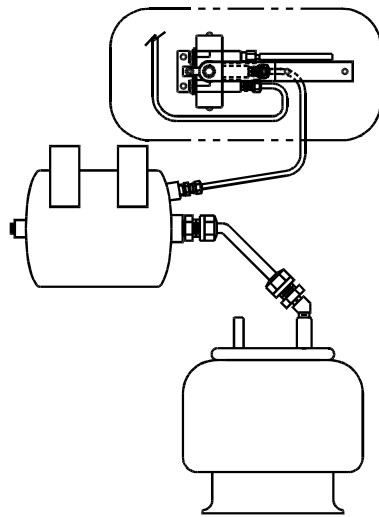

Installation on units without dump valves.

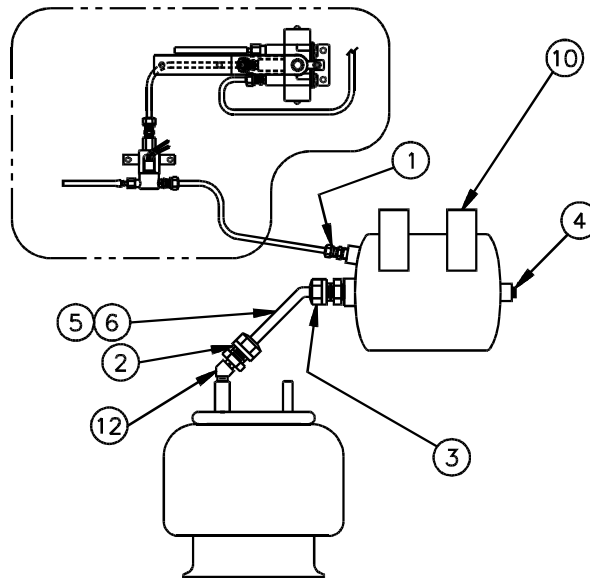

Installation on units with dump valves.

Notes:

1. For best results, the ping tank should be mounted as close to the air spring as possible.
2. If the air system contains "kneeler" dump valves, the above tank system must be inserted between the "kneeler" valve and the air spring.

REPLACEMENT INSTRUCTIONS & WARRANTY

R-SERIES

Replacement Instructions

NOTE: Due to the nature of service to be performed it is recommended that a qualified mechanic do the work.



Limited Warranty

ReycoGranning® warrants its R-Series suspensions to be free from defects in material and workmanship under normal use and service in the U.S. and Canada.

Main Structural Components -- 24 months or 50,000 miles, whichever occurs first. Defined as: hangers, beams, clip plates and axle saddles.

Other Air Suspension Components -- 12 months or 24,000 miles, whichever occurs first - valves, fasteners, bushings, and other components not stated specifically (when provided by ReycoGranning®), and other fabricated metal components. ReycoGranning® provides no warranties on components such as axles, air springs, controls, air compressors, brakes, shock absorbers, and hub and drum assemblies, except to the extent of any warranty provided to ReycoGranning® Suspensions by the manufacturer of such components.

Labor -- 6 months or 12,000 miles whichever comes first. Labor will be allowed on ReycoGranning® Suspensions estimated time to make repairs at a maximum rate of \$50.00 per hour. As used herein, the term "normal use and service" means that the suspension will be installed, operated, inspected and maintained in accordance with the applicable ReycoGranning® Suspensions owner's manual, and any applicable vehicle owner's manual or instructions.

Adjustments

The starting date for the above warranty period is the date of purchase of the suspension by the first end user. Proof of such date is the responsibility of the first end user. If the purchase date is not established to ReycoGranning® Suspensions satisfaction, the date of manufacture determined from the suspension system's serial number shall be used as the effective starting date. When adjustment is sought under this warranty, a claim should be made by contacting the distributor or manufacturer who installed the suspension, who will coordinate the fix, documentation, parts shipment, etc. directly with ReycoGranning® Suspensions.

***NOTE* ReycoGranning® Suspensions must be notified in writing using a warranty claim form promptly upon claimed defect.**

INSTALLER AND END USER RESPONSIBILITIES

The Distributor/Installer is responsible for installing the product according to ReycoGranning® Suspensions approved procedures, the installer is also responsible (either directly or through its agent/dealer) for providing a copy of ReycoGranning® Suspensions warranty and owner's manual to the end user, and for advising the end user of proper use, service and maintenance required for the product. The end user is responsible for operating, inspecting and maintaining the suspension according to the instructions in the ReycoGranning® Suspensions owner's manual and any applicable vehicle owner's manual, and for properly instructing all operators and maintenance personnel.

***NOTE* Warranty may be denied for improper installation.**

LIMITATIONS AND EXCLUSIONS

No warranty applies in the event of: use of components, parts and/or accessories not obtained from or approved by ReycoGranning® Suspensions or which do not meet ReycoGranning® Suspensions quality and performance specifications; improper installation, maintenance or repair; misuse or abuse including but not limited to overloading; or unauthorized alterations or modifications.

THE ABOVE WARRANTIES ARE SUBJECT TO THE "WARRANTY LIMITATIONS" AND "REMEDIES" SECTIONS OR REYCOGRANNING® SUSPENSIONS INVOICE TERMS AND CONDITIONS.

This policy supersedes any previous warranty statements.

03/2005



1075 West 9th Street, Fort Collins, CO
80521-1100
Tel: 970.226.8291 Fax: 970.226.8290
www.tuthill.com

INSTALLATION INSTRUCTIONS

Referenced Drawings

RD1200DA Suspension Installation Drawing, D708755

(Refer to drawing D708755 for all item numbers and views specified in this document.)

Height Control Valve Installation Drawing, D709008

General

Follow the step by step procedure below in the order given for proper installation. Read the instructions thoroughly before starting installation.

CAUTION: A minimum of 3 inches clearance must be maintained between tailpipe and air spring. This may require alteration and/or relocation of the tailpipe. All modifications to the tailpipe must be in accordance with vehicle manufacturer's recommendations. See Body Builders Layout Book.

VEHICLE PREPARATION:

1. Secure vehicle by blocking the steering axle wheels and supporting the frame aft of drive axle.
2. Raise drive axle to clear tires of ground and support axle.
3. Remove tires.
4. Remove the rear helper spring brackets and the leaf springs with rear shackles.

NOTE: Retain all fasteners for air suspension installation.

5. Remove the jounce bumpers from the frame rails.
6. Clear all electric, fuel, and hydraulic lines in area of frame of air suspension mounting. **NOTE:** Do not brake or disconnect any electrical, fuel or hydraulic lines.

FRAME DRILLING:

1. Wear Block and Upper Air Spring Pad Location
 - Use upper air spring pad assemblies, items 708741-01 & 708741-02 as templates. Drill four Ø.531 holes per side. Use backing plate assemblies, items 708539-01 & 708539-02 as templates. Drill four Ø.438 holes per side. See drawing sheet 3 for proper location on frame. Use existing holes where available and drill out, if necessary.

AIR SUSPENSION MOUNTING:

1. Backing Plate Assembly Installation

1.1. Materials:

- 1 - backing plate assembly, left - 708539-01
- 1 - backing plate assembly, right - 708539-02
- 4 - flange head bolt 3/8-16 x 1.25 - 302
- 4 - locking flange nut 3/8-16 - 702605-01
- 4 - Hex head bolt M12-1.75x110 - 708159-01
- 4 - Lock Washer 1/2 - 8103323

1.2. Instructions

- Install backing plate assemblies, items 708539-01 & 708539-02 using the previously drilled holes and the fasteners 302 & 702605-01. Install items 708159-01 & 8103323 in the jounce bumper holes. See drawing sheet 2 for proper installation.

INSTALLATION INSTRUCTIONS

- Torque items 702605-01 & 708159-01 to 80 ft-lbs.
2. Wear Pad
 - 2.1. Materials:
 - 1 – wear pad, left - 708578-01
 - 1 – wear pad, right - 708578-02
 - 4 – flat countersunk hex screw 3/8-24 x 1.50 – 4356
 - 4 – flat countersunk hex screw 3/8-24 x 2.00 – 298
 - 8 – locking flange nut 3/8-24 – 304
 - 2.2. Instructions:
 - Install wear pads, items 708578-01 & 708578-02 to the backing plate assemblies using the available holes and the fasteners listed above. See drawing sheet 2 for proper installation.
 - Torque to 100 in-lbs.
 3. Upper Air Spring Pad Installation
 - 3.1. Materials:
 - 1 – upper air spring pad assembly, left - 708741-01
 - 1 – upper air spring pad assembly, right - 708741-02
 - 8 – flange head bolt 1/2-13 x 1.75 – 276
 - 8 – locking flange nut 1/2-13 – 308
 - 1 – reinforcement channel, left - 701980-01
 - 1 – reinforcement channel, right - 701980-02
 - 3.2. Instructions:
 - Install the reinforcing channel, item 701980-01 & 701980-02, inside of the frame rail. Install upper air spring pad assemblies, items 708741-01 & 708741-02 using the previously drilled holes and the fasteners listed above. See drawing sheet 2 for proper installation.
 - Torque to 90 ft-lbs.
 4. Spring Beam Installation
 - 4.1. Materials:
 - 2 – spring beam assembly - 708395-01
 - 2 – existing pivot bolt
 - 2 – existing nut
 - 4.2. Instructions:
 - Install spring beam assemblies, item 708395-01 to the hangers using the fasteners listed above. **Do NOT tighten at this time.**
 5. Axle Wedge Assembly Installation
 - 5.1. Materials:
 - 1 – axle wedge assembly, left - 708537-01
 - 1 – axle wedge assembly, right - #24(708537-02)
 - 5.2. Instructions:
 - Install axle wedge assemblies, items #23(708537-01) & #24(708537-02) in between axle seats and spring beam assemblies. See drawing sheet 2 for proper installation. Be sure axle wedge assemblies are positioned correctly; they must be centered on spring seats and parallel to them for proper axle alignment.
 6. Wear Tower Assembly Installation
 - 6.1. Materials:
 - 2 – Wear tower assembly - #27(708544-01)
 - 4 – U-bolt - #19(705059-01)
 - 8 – flat washer 3/4 .812x1.475x.150- #2(103003)
 - 8 – Lock high nut 3/4-16 - #15(6868)

INSTALLATION INSTRUCTIONS

- 2 – lower clip plates – (Re-use OEM lower clip plates)

6.2. Instructions:

- Install wear tower assemblies, item #27(708544-01) onto the spring beam assemblies using the fasteners listed above.
- Re-install lower clip plates (OEM). See drawing sheet 2 for proper installation. **Do NOT tighten at this time.**

7. Lower Air Spring Pad Assembly and Air Spring Assembly Installation

7.1. Materials:

- 2 – lower air spring pad assembly - #36(709094-01)
- 4 – hex head bolt 1/2-20 x 3.50 - #3(127)
- 4 – lock nut 1/2-20 - #47(89422302)
- 2 – air spring assembly - #45(8609)
- 2 – hex head bolt 1/2-13 x 4.50 - #12(5559)
- 2 – nut 1/2-13 - #39(8120378)
- 2 – slotted lock washer 1/2 - #41(8120384)
- 2 – flat washer 1/2 .531x1.250x.100- #2(89415543)
- 2 – jam nut 3/4-16 - #44(8219758)
- 2 – slotted lock washer 1/2 - #42(8131017)

7.2. Instructions:

- Drop hex head bolts, item #3(127) down in the two outside holes in lower air spring pad assemblies, item #36(709094-01). Place hex head bolts, item #12(5559) up through middle hole in lower air spring pad assemblies. Attach air spring assemblies, item #45(8609) to hex head bolt, item #12(5559). Position air spring assemblies so that the top studs line up with their mounting holes in the upper air spring pad assemblies. See drawing sheet 2 for proper installation.
- Torque item #12(5559) to 30 ft-lbs.
- Install the lower air spring pad assemblies with hex head bolts, item #3(127) in the available holes in the spring beam assemblies using lock nuts, item #47(89422302). See drawing sheet 2 for proper installation.
- Torque to 90 ft-lbs.
- Install air spring assemblies to the upper air spring pad assemblies using the available holes, and nuts, items #39(8120378), #41(8120384), #2(89415543), #44(8219758), and #42(8131017). See drawing sheet 2 for proper installation.
- Torque to 35 ft-lbs.

8. Axle Alignment

8.1. Materials:

- None

8.2. Instructions:

- Make sure the spring beam assemblies are positioned properly. The spring beam assemblies must be attached properly to the axle wedge assemblies and the axle wedge assemblies must be attached properly to the axle seats with no space between any of them. Make sure they are parallel to each other. Position and support the axle at ride height.
- Torque spring beam pivot bolts to 480 ft-lbs.
- Make sure there is no space between the wear tower assemblies and the spring beam assemblies and they are parallel to each other.
- Verify the clip plate wear towers are equally spaced on both sides from the wear blocks and located approximately .090" to .120" away from the wear blocks. If not, adjust axle location and/or clip plate assembly locations to achieve this. Refer to drawing sheet 1, section A-A.

INSTALLATION INSTRUCTIONS

- Torque u-bolt nuts, item #8(6868) to 250 ft-lbs. A criss-cross pattern must be used to torque these.
- **AXLE ALIGNMENT NOTE:** An improperly aligned axle will result in premature wear of vehicle's tires and suspension wear pads.

9. Height Control Valve Installation

9.1. Materials:

- 4 – hex head bolt 1/4-20 x .75 – (8180020)
- 4 – Nut 1/4-20, Gr5 – (8120375)
- 4 – SLW 1/4 - (8120380)
- 2 – height control linkage and studs – (6105)
- 2 – height control valve – (5608)

9.2. Instructions:

- Install height control valve linkage pins using fasteners provided with 4458. See drawing D709008 for proper installation and correct orientation.
- Torque to 60-80 in.lbs.
- Install height control valve linkage as shown. See drawing D709008 for proper installation.

INSTALLATION CHECK LIST

Suspension Information: RD1200DA

Installer:	Installation Date:
Inspector:	Inspection Date:
Model Number:	Suspension Serial Number:
V.I.N. Number:	
Air Kit:	Options:

Referenced Drawings

Installation Drawing D708755
Height Control Valve Kit D709008
Air Control Kit D706859 (RD1200DA-AB)
9930 (RD1200DA-4)
9932 (RD1200DA-5)
D709308 (RD1200DA-QR)

1 Frame Drilling

- Hole position as required on installation drawing. Note: Holes must be drilled, not torched.

2 Wear Block Installation

- Backing plate installed.
- Mounting bolts properly torqued. Torque measured at _____.
- Wear block mounting bolts not overtorqued (wear block not warped). Torque measured at _____.

3 Beam Installation

- Pivot bolts reinstalled correctly.
- Pivot bolt torque correct at ride height. Torque measured at _____.
- Beam alignment pin seated correctly in spacer.
- Spacer alignment pin seated correctly in axle mount (seat).

4 Clip Plate and U-Bolt Installation

- Clip plate installed with correct orientation.
- U-bolts installed and torqued correctly at ride height. Torque measured at _____.
- Clearance between wear tower and wear block correct. Clearance measured at _____.

5 Air Spring Installation

- Air spring position correct and installed without any twist
- Adequate clearance around air spring to prevent chafing, puncturing, or overheating (from exhaust). Recommend 1" clearance around air spring to prevent chafing or puncturing. Recommend min. 3" clearance to any part of the exhaust system.

6 Height Control Valve (HCV) Installation

- HCV positioned correctly with clearance around air springs.
- Linkage installed correctly with clearance around air springs.
- Linkage is the correct length (9.75").
(1) Linkage length is _____.
- Air lines installed to proper port on HCV (see Height Control Valve Installation Drawing, D709008).

7 Air Kit Installation

- Air tank assy. installed correctly (Automatic moisture emitter on bottom of tank).
- Dump Valve (kneeler valve) installed with exhaust port down.
- All air line fittings to be installed with Permatex sealant or equivalent on threads. Teflon tape is not to be used.
- Air line SAE DOT brake line and protected in the installation with loom to prevent chafing or pinching on sharp edges.

INSTALLATION CHECK LIST

- Electrical line wired correctly with 10 AWG. min. wire and protected to prevent cutting or chafing. NOTE: Improper wire size may cause compressor failure.
- Air lines and wiring installed without loops or bends.
- Verify check valve orientation out of the compressor head, arrow is to point away from compressor.
- Air Compressor installed in a well ventilated enclosure and wired correctly (positive to terminal labeled A1 & negative to terminal labeled A2). NOTE: Enclosure must protect the compressor from adverse environmental conditions (see compressor decal). Failure to do so may void warranty.
- Air compressor higher than tank assy.
- Check air compressor operation.
- Verify ride height. Remove excess linkage rod to prevent readjustment. _____ Height measured.
- Check air system for air leaks using a soapy water solution.

8 8 . Ping Tanks

- Ping tanks installed as close as possible to the air springs.
- All air line fittings to be installed with Permatex sealant or equivalent on threads. Teflon tape is not to be used.
- Air line SAE DOT brake line and protected in the installation with loom to prevent chafing or pinching on sharp edges.

9 Additional Observations and Comments